

Operating Instructions

Included Installation Instructions

Mount Bracket

Model No. **WV-Q186**

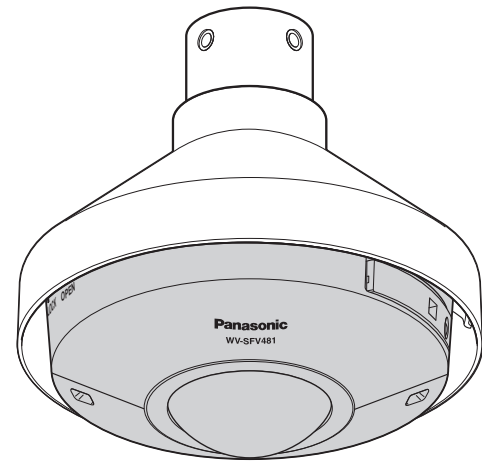

Before attempting to connect or install this product, please read these instructions carefully and save this manual for future use.

The model number is abbreviated in some descriptions in this manual.

<p>For U.S. and Canada:</p> <p>Panasonic i-PRO Sensing Solutions Corporation of America 800 Gessner Rd, Suite 700 Houston, TX 77024 https://www.security.us.panasonic.com/</p> <p>Panasonic Canada Inc. 5770 Ambler Drive, Mississauga, Ontario, L4W 2T3 Canada 1-877-495-0580 https://www.panasonic.com/ca/</p>	<p>For Europe and other countries:</p> <p>Panasonic Corporation http://www.panasonic.com</p> <p>Panasonic i-PRO Sensing Solutions Co., Ltd. Fukuoka, Japan</p> <p>Authorised Representative in EU:</p> <p>Panasonic Testing Centre Panasonic Marketing Europe GmbH Winsbergring 15, 22525 Hamburg, Germany</p>
--	--

Specifications

Ambient operating temperature: -50 °C to +60 °C [-58 °F to 140 °F]	
Dimensions:	Maximum diameter: ø176 mm {6-15/16 inches} Height: 131 mm {5-5/32 inches}
Mass:	Approx. 480 g {1.06 lbs}
Finish:	Main body: Aluminum die cast Light grey

Preface

Features

WV-Q186 (mount bracket) is designed to be used to install a fisheye camera or a dome camera for outdoor use in the following ways.

- When installing on a wall using together with WV-Q185 (wall mount bracket)

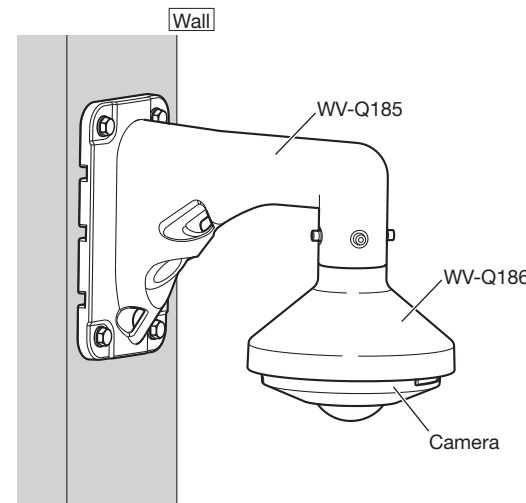

Precautions

Refer installation work to the dealer.

Installation work requires technique and experiences. Failure to observe this may cause fire, electric shock, injury, or damage to the product. Be sure to consult the dealer.

Periodic inspections shall be conducted.

Rust on the metal parts or screws may cause a fall of the product resulting in injury or accidents. Consult the dealer for the inspections.

The exclusively designed mount bracket shall be used.

Failure to observe this may cause a drop resulting in injury or accidents. Use the exclusively designed mount bracket for installation.

The screws and bolts must be tightened to the specified torque.

Failure to observe this may cause a drop resulting in injury or accidents.

Select an installation area that can support the total weight.

Selecting an inappropriate installation surface may cause this product to fall down or topple over, resulting in injury or accidents. Installation work shall be started after sufficient reinforcement.

Do not install this product in locations subject to vibration.

Loosening of mounting screws or bolts may cause a fall of the product resulting in injury or accidents.

Install this product in a location high enough to avoid people and objects from bumping the product.

Failure to observe this may cause injury.

The measures of protection against snowfall shall be taken.

Weight of snow may cause a fall of the product resulting in injury or accidents. Protect the product against snowfall by installing under eaves.

Avoid installing this bracket in the locations where salt damage occurs or corrosive gas is produced.

Otherwise, the mounting portions will deteriorate and accidents such as a fall of this product may occur.

Do not hang down from this product or use this product as a pedestal.

Failure to observe this may cause injury or accidents.

Do not install this product on a place that is greatly influenced by wind.

Installation on a place where the wind speed is 60 m/s (approx. 134 mph) or more may cause a fall of the product resulting in injury or accidents.

Do not use this bracket except with specified cameras.

Failure to observe this may cause a drop resulting in injury or accidents.

Do not rub the edges of metal parts with your hand.

Strong rubbing may cause injury.

Precautions for installation

Panasonic assumes no responsibility for injuries or property damage resulting from failures arising out of improper installation or operation inconsistent with this documentation.

Take notice of humidity.

Install this product when the humidity is low. If installation is performed when it is raining or in very humid conditions, the inside may be affected by humidity, causing mist-over inside the camera.

Mounting method for this product

This product is designed to be used as a pendant mount camera. If the product is mounted on a desktop or at a slant, it may not work correctly and its lifetime may be shortened.

Do not place this product in the following places:

- Locations where a chemical agent is used such as a swimming pool
- Locations subject to moisture or oil smoke such as a kitchen
- Locations that have a specific environment that is subject to an inflammable atmosphere or solvents
- Locations where radiation, an x-ray, a strong radio wave, or a strong magnetic field is generated
- Locations near coasts directly subjected to sea breezes, or locations subject to corrosive gases such as from hot springs, volcanic regions, etc.
- Locations subject to condensation as the result of severe changes in temperature (The ambient operating temperature of the installed camera.)
- Locations subject to condensation as the result of severe changes in temperature (In case of installing the product in such locations, the inside of camera may become foggy or condensation may be caused in the camera.)
- Locations subject to vibrations, such as on vehicles, marine vessels, or above product lines (This product is not designed for on-vehicle use.)

Screw tightening

- Do not use an impact driver. Use of an impact driver may damage the screws or cause tightening excessively.
- When a screw is tightened, make the screw at a right angle to the surface. After tightening the screws or bolts, perform checks to ensure that the tightening is sufficient enough so that there is no movement or looseness.

Protection from lightning

When cables are used outdoors, there is a chance that they may be affected by lightning. In such a case, install a lightning arrester close to the camera, and make the length of the network cable between the camera and lightning arrester as short as possible to prevent the camera from being damaged by lightning.

Make sure to remove this product if it will no longer be used.

<Mountable models>

The following cameras for outdoor use can be mounted on WV-Q186. For the latest information about the mountable models, refer to Panasonic support web site (<https://security.panasonic.com/support/info/>).

Network Camera: WV-SFV631LT, WV-SFV631L, WV-SFV611L, WV-SFV531, WV-SFV311A, WV-SFV310A, WV-S2531LTN, WV-S2531LN, WV-S2511LN, WV-SFV481, WV-SW458
CCTV Camera: WV-CW634S, WV-CW634SE, WV-CW634F, WV-CW630S/G, WV-CW364SE, WV-CW334SE

Parts and functions

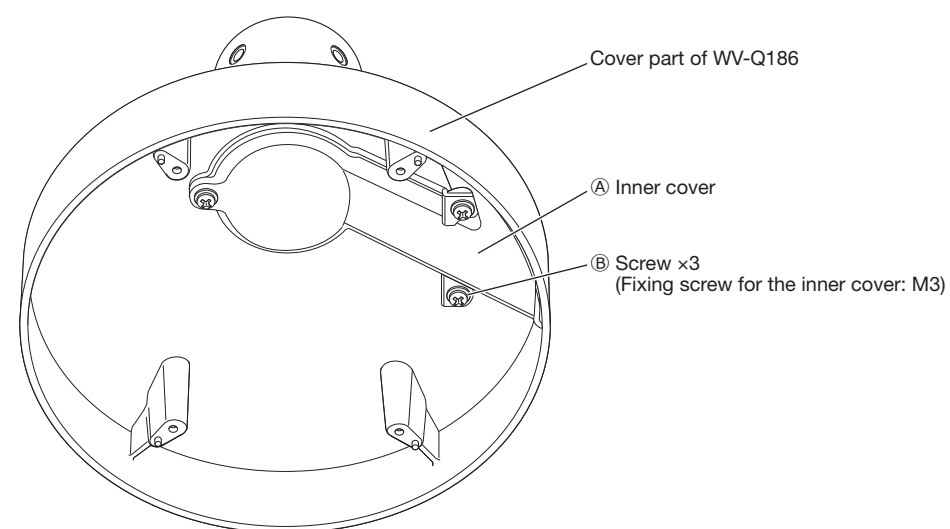

Installations/Connections

[1] Fix WV-Q185 (wall mount bracket) on a wall and attach the cover of WV-Q186 (mount bracket) to the WV-Q185

① Pass the cables from the wall to the WV-Q185. Adjust the length of the cables so that the cables of approx. 300 mm {11-13/16 inches} come out from the opening of the WV-Q185.

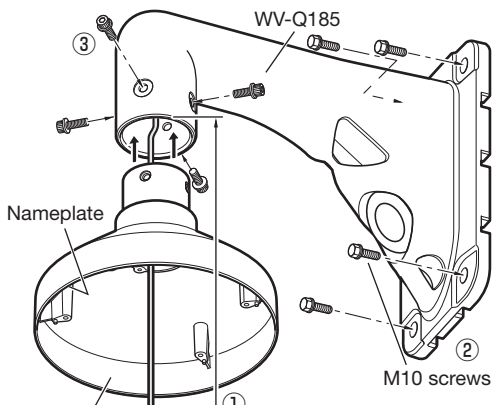

Note:
 • Do not bundle the cables (Ethernet cable, power cable, etc.) during installation. Mounting of (A) inner cover (accessory) may become difficult. (The provided illustration shows the Ethernet cable as a representative image.)

② Fix the WV-Q185 on a wall with M10 screws (locally procured) or four anchors (locally procured). Minimum pull-out strength: 823 N {185 lbf}/per 1 pc.
 * Refer to the operating instructions of WV-Q185 for further information on how to fix.

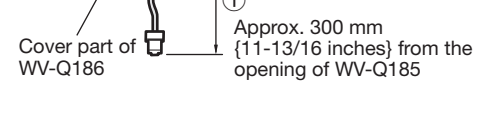

③ Attach the cover part of the WV-Q186 to the WV-Q185, and then fix it with M6 hex socket screws (provided with WV-Q185). (A hex wrench for M6 is required.) (Recommended tightening torque: 2.45 N-m {1.81 lbf-ft})
 * Fix the cover so that the nameplate of the WV-Q186 comes in front of the WV-Q185.

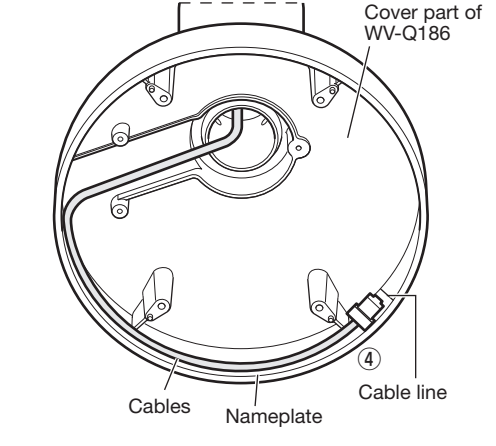

④ After fixing the WV-Q186 on the WV-Q185, lay the cables as shown in the upper right illustration and confirm that the ends of the cables reach the cable line inside the cover of the WV-Q186.

[2] Fix the cable with the inner cover of WV-Q186

① Wire the cables as shown below.
 ② Fix (A) inner cover (accessory) using (B) screw (M3: accessory). (Recommended tightening torque: 0.78 N-m {0.58 lbf-ft})

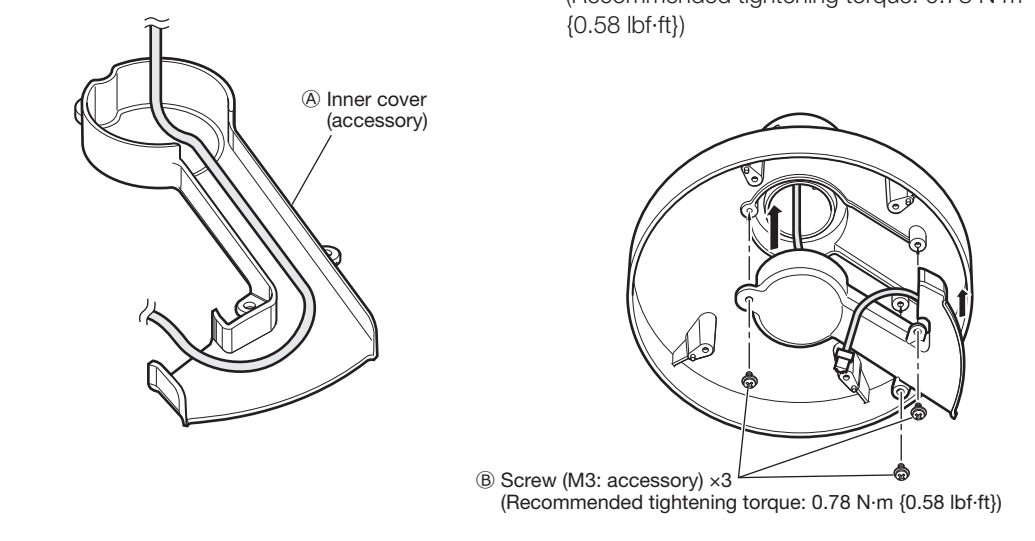

[3] Attach the attachment plate to the cover part of the WV-Q186

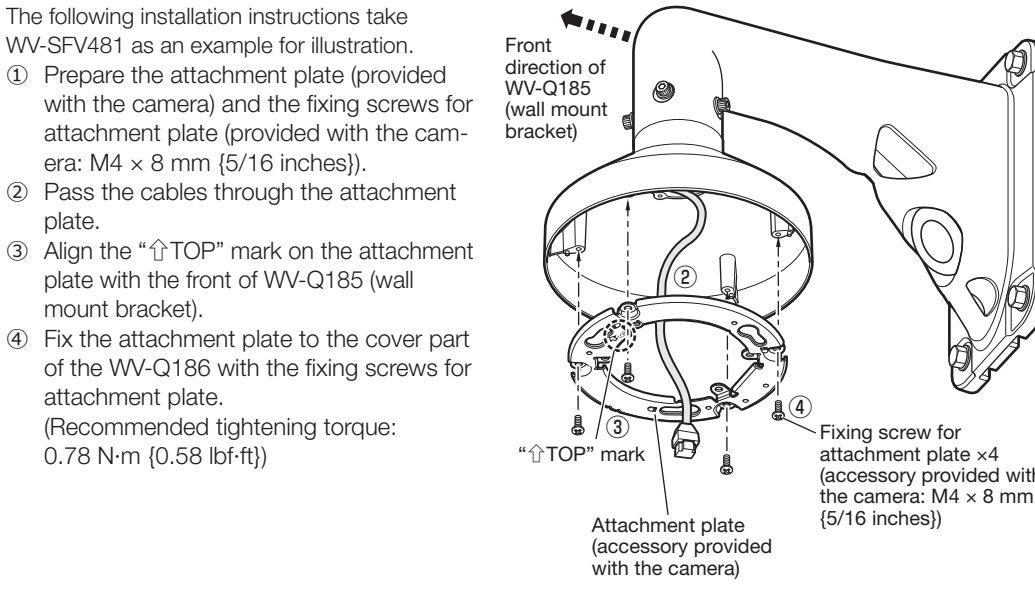

The following installation instructions take WV-SFV481 as an example for illustration.
 ① Prepare the attachment plate (provided with the camera) and the fixing screws for attachment plate (provided with the camera: M4 x 8 mm {5/16 inches}).
 ② Pass the cables through the attachment plate.
 ③ Align the "TOP" mark on the attachment plate with the front of WV-Q185 (wall mount bracket).
 ④ Fix the attachment plate to the cover part of the WV-Q186 with the fixing screws for attachment plate. (Recommended tightening torque: 0.78 N-m {0.58 lbf-ft})

* The upper right illustration is provided as an example of attaching the attachment plate for a camera model having three attachment mounting screws.

[5] Fix the camera to the attachment plate

① After connecting the cables to the camera, align the OPEN mark at the side of the camera enclosure to the claw of the attachment plate (provided with the camera). Then, insert the attachment mounting screws (2 or 3 points) at the bottom of the camera into the holes of the attachment plate.
 After that, move the LOCK mark to the point where the claw of the attachment plate is located by rotating the camera body clockwise by approx. 15° to fix temporarily.
 * Refer to the operating instructions of the connected camera for information on how to mount the camera.

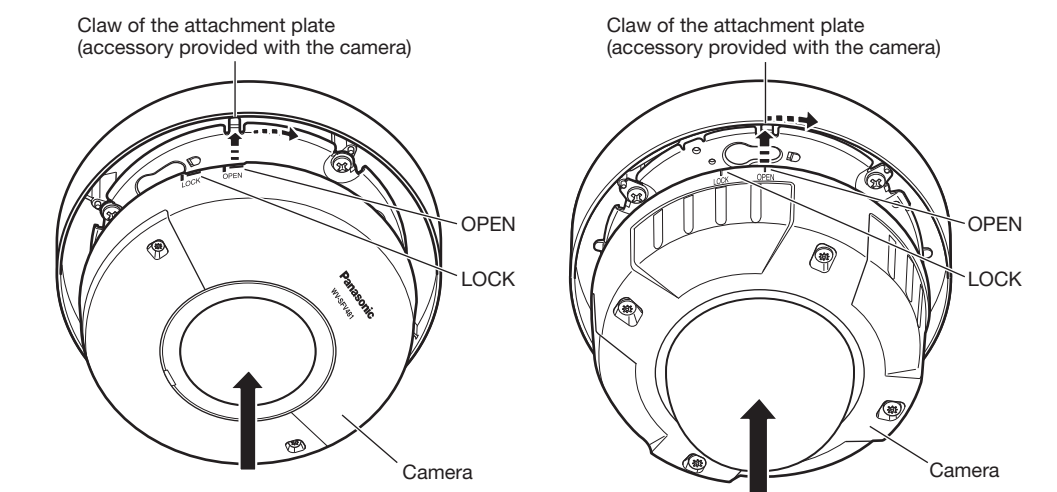

<Example of mounting WV-SFV481> <Example of mounting WV-SFV631L>

IMPORTANT:
 • When using WV-SFV481 or WV-SW458 with a SD memory card, insert the SD memory card to the camera before mounting the camera onto the WV-Q186.

② Fix the camera to the attachment plate. For the mounting method of the camera, please refer to the Installation Guide of each camera.

<For WV-SFV481>

1. Loosen two of the sub cover fixing screws using the bit (provided with the camera) and remove the sub cover of the camera. Then, tighten the camera fixing screw to fix the attachment plate and the camera. (Recommended tightening torque: 0.78 N-m {0.58 lbf-ft})

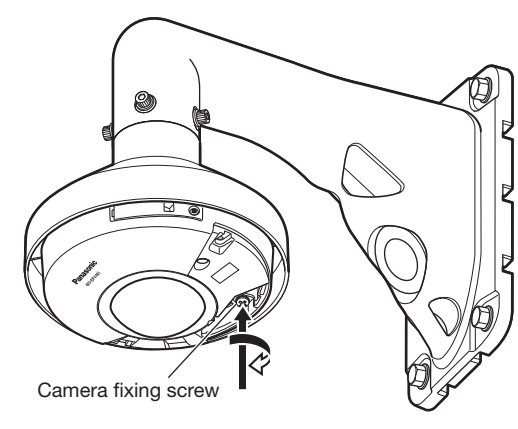

2. Attach the sub cover back to the original position and fix with two of the sub cover fixing screws.
 * The sub cover is omitted in the illustration.

<For WV-SW458>
 Tighten the camera fixing screw located at the enclosure of the camera to fix the attachment plate and the camera. (Recommended tightening torque: 0.78 N-m {0.58 lbf-ft})

<For cameras other than the above>
 1. Loosen the fixing screws (3 or 4 screws) of the enclosure using the bit and remove the enclosure from the camera body. Then, fix the camera with the camera fixing screw. (Recommended tightening torque: 0.78 N-m {0.58 lbf-ft})

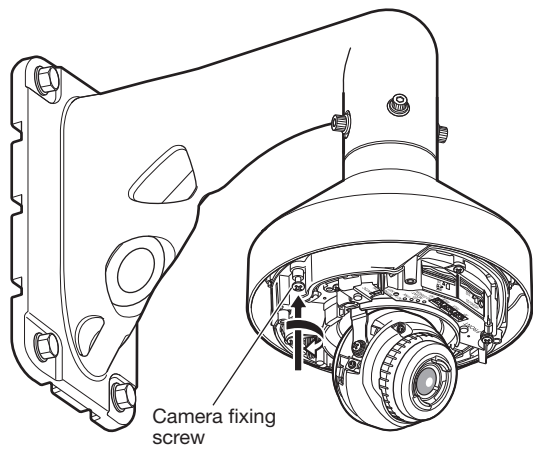

* The enclosure is omitted in the illustration. WV-SFV631L is used as an example in the above illustration.

IMPORTANT:
 • Enclosure is fixed at the installation auxiliary wire to the camera body, please do not remove the installation auxiliary wire.

Note:
 • As for the enclosure fixing screw, there are three screws models and four screws models depending on the camera model. Refer to the operating instructions of the camera for further information.

2. Adjust images from the camera.
 * Refer to the operating instructions of the camera for further information on how to adjust.

3. After completing the adjustment, attach the enclosure back to the original position and fix it with the enclosure fixing screws (3 or 4 screws).

IMPORTANT: This caution shall be applied to all the cameras as described above.
 • Be sure to tighten the camera fixing screw. Failure to observe this may cause camera trouble due to camera falling. (Recommended tightening torque: 0.78 N-m {0.58 lbf-ft})

[4] Making connections

Applicable models:
Network Camera: WV-SFV631LT, WV-SFV631L, WV-SFV611L, WV-SFV531, WV-SFV311A, WV-SFV310A, WV-S2531LTN, WV-S2531LN, WV-S2511LN, WV-SFV481, WV-SW458
CCTV Camera: WV-CW634S, WV-CW634SE, WV-CW634F, WV-CW630S/G, WV-CW364SE, WV-CW334SE
 * WV-SFV481 is used as an example in the right illustration.

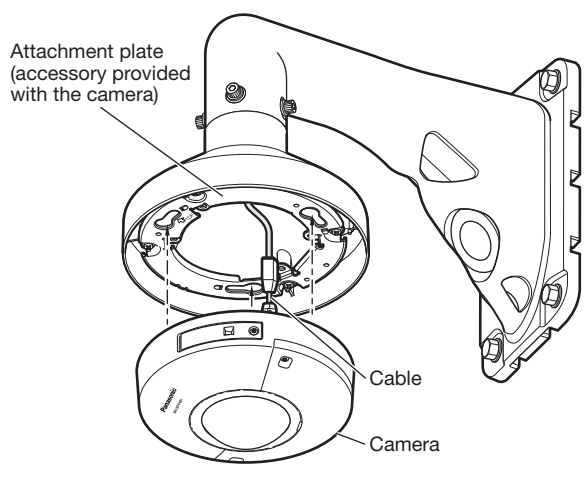

① Connect the cables passed through the plate in section [3] with the cables from the camera.

* For information on cable connection, please refer to the relevant camera usage instructions.

② Apply waterproof treatment to the joints of the cables.

<When waterproof treatment is applied to RJ45 connector and other cables>

Adequate waterproof treatment is required for the cables when installing the camera with cables exposed. The camera body is waterproof, but the cable ends are not waterproof. Be sure to use the waterproof tape provided with the camera at the points where the cables are connected and apply waterproof treatment in the following procedure. Failure to observe this or use of a tape other than the provided waterproof tape (such as a vinyl tape) may cause water leakage resulting in malfunction. Separately apply waterproof treatment to the network cable and other cables as shown in the illustration below.

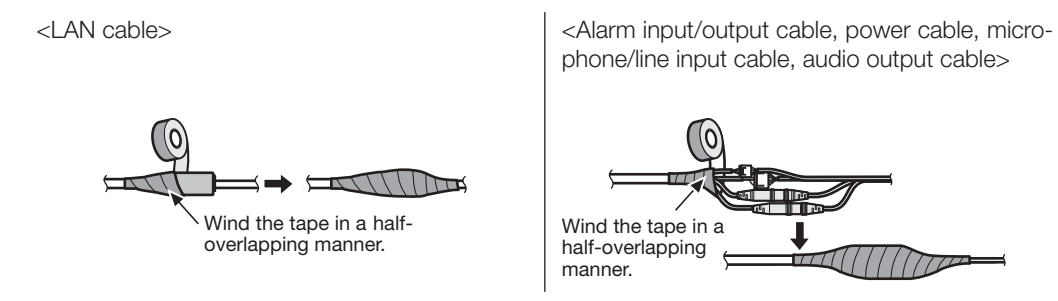

IMPORTANT:

- Also waterproof the 2P power cable (provided with the camera), 4P alarm cable (provided with the camera), and external connections in the same way.
- Stretch the tape by approx. twice (see the illustration at right) and wind it around the cable. Insufficient tape stretch causes insufficient waterproofing.
- Waterproof grade (JIS IP66 or equivalent) is applied to this product only when it is installed correctly and also an appropriate waterproof treatment is applied. The inner side of WV-Q186 (mount bracket) is not waterproofed.
- When a LAN cable cover is provided with the camera in the package, attach the LAN cable cover to the cable as shown in the illustration and fix it by sliding to the direction indicated by the arrow. The connector of the LAN cable used with this camera must meet the following restrictions.

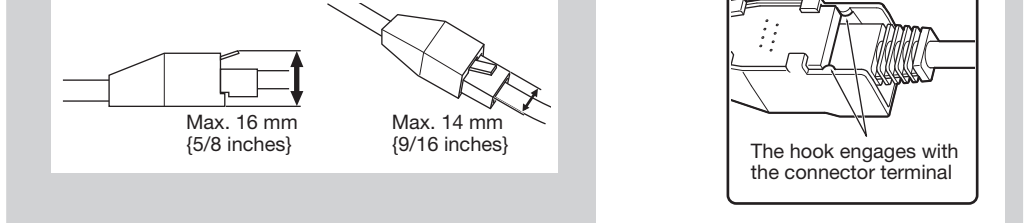

<If RJ45 waterproof connector is used> Connect an Ethernet cable (category 5e or better, straight) to RJ45 plug (locally procured).

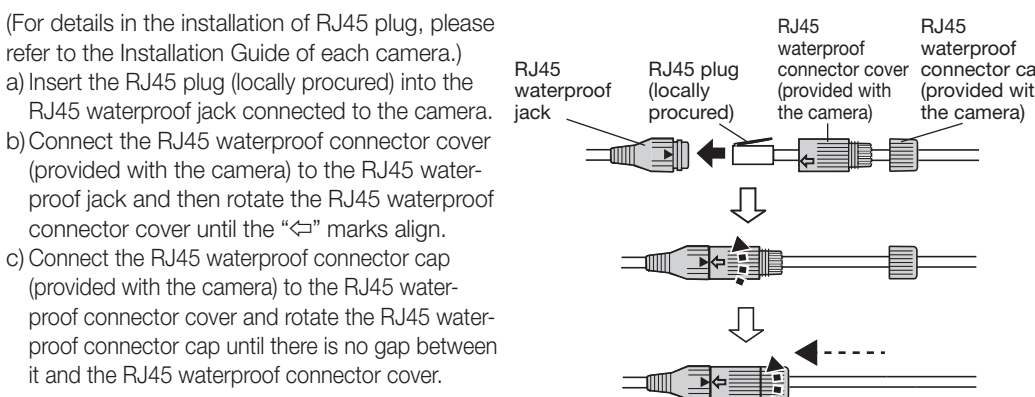

(For details in the installation of RJ45 plug, please refer to the Installation Guide of each camera.)
 a) Insert the RJ45 plug (locally procured) into the RJ45 waterproof jack connected to the camera.
 b) Connect the RJ45 waterproof connector cover (provided with the camera) to the RJ45 waterproof jack and then rotate the RJ45 waterproof connector cover until the "←" marks align.
 c) Connect the RJ45 waterproof connector cap (provided with the camera) to the RJ45 waterproof connector cover and rotate the RJ45 waterproof connector cap until there is no gap between it and the RJ45 waterproof connector cover.

IMPORTANT:
 • If the procedure for the RJ45 waterproof connector (provided with the camera) part is not correctly followed, the waterproofing may be compromised. Do not install the camera where the RJ45 waterproof connector is exposed to constant rain or moisture.
 • When you remove the RJ45 waterproof connector, be sure to follow the reverse order of the connecting procedures. (The RJ45 waterproof jack may be damaged when you try to remove the RJ45 waterproof connector cover with its "←" mark matching "▶" mark of the RJ45 waterproof jack.)