

Panasonic®

Operating Instructions

Ceiling Mount Bracket

Model No. WV-Q159C

WV-Q159S

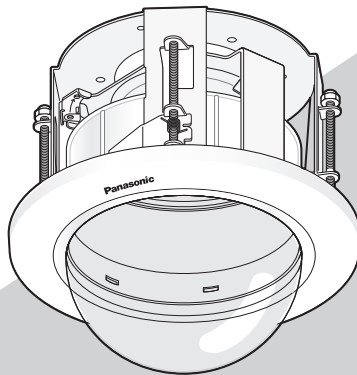

Before attempting to connect or operate this product,
please read these instructions carefully and save this manual for future use.

The model number is abbreviated in some descriptions in this manual.

CONTENTS

Preface	3
Precautions	3
Precaution for installation.....	5
Parts and functions	6
Installations	7
Specifications.....	14
Standard Accessories	14

Preface

This ceiling mount bracket is exclusively designed to mount the network camera on a ceiling. Refer to the catalog or the installation guide of the camera for supported cameras.

This bracket can be used for an area with weak pull-out strength such as plasterboard in a double ceiling.

This bracket is an embedded type to reduce the exposed portion of the camera body.

- WV-Q159C: Clear dome cover
- WV-Q159S: Smoked dome cover (approx. 50 % of transmittance)

Precautions

- **Do not hang down from this product or use this product as a pedestal.**

Failure to observe this may cause a drop resulting in accidents.

- **Use only the specified camera.**

Failure to observe this may cause a fall of an inappropriate camera resulting in injury or accidents. Refer to the catalog or the installation guide of the camera for supported cameras

- **Avoid installing this bracket in the locations where salt damage occurs or corrosive gas is produced.**

Otherwise, the mounting portions will deteriorate and accidents such as a fall of the camera may occur.

- **Refer installation work to the dealer.**

Installation work requires technique and experience. Failure to observe this may cause fire, electric shock, injury, or damage to the product. Be sure to consult the dealer.

- **Do not install this product in locations subject to vibration.**

Loosening of mounting screws or bolts may cause a fall of the product resulting in injury or accidents.

- **Install this product in a location high enough to avoid people and objects from bumping the product.**

Failure to observe this may cause injury.

- **The measures of protection against a fall of the camera shall be taken.**

Failure to observe this may cause a drop resulting in injury. Be sure to install this bracket-specific safety wire.

- **The screws and bolts must be tightened to the specified torque.**

Failure to observe this may cause a drop resulting in injury or accidents.

- **Periodic inspections shall be conducted.**

Rust on the metal parts or screws may cause a fall of the product resulting in injury. Consult the dealer for the inspections.

- **Select an installation area that can support the total weight.**

Selecting an inappropriate installation surface may cause this product to fall down or topple over, resulting in injury or accidents. Installation work shall be started after sufficient reinforcement.

- **Install this product on a ceiling according to the instructions.**

Failure to observe this may cause injury or injury or accidents.

- **Do not rub the edges of metal parts with your hand.**

Failure to observe this may cause injury.

Precaution for installation

In order to prevent injury, the product must be securely mounted to a ceiling according to Installation Guide. This product is designed to be used indoors. This product is not operable outdoors.

- Consult the dealer about the installation area to select a strong ceiling area. Make sure that the installation area is strong enough to hold the total weight of the camera assembly (approx. 1.9 kg {4.2 lbs.}) before installation.
- The installation area shall have 180 mm {7-1/8 inches} or more space behind the ceiling.

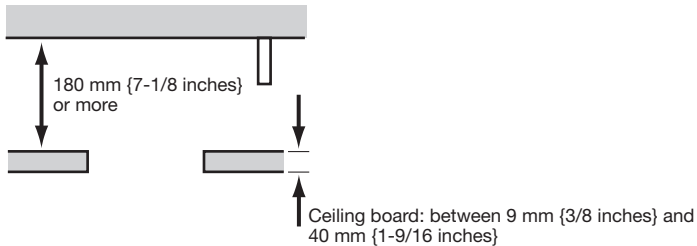

- The thickness of the ceiling board for installation can range between 9 mm {3/8 inches} and 40 mm {1-9/16 inches}.
- Do not place this product in the following places.
 - Locations where a chemical agent is used such as a swimming pool
 - Locations subject to moisture or oil smoke such as a kitchen
 - Locations that have a specific environment that is subject to an inflammable atmosphere or solvents
 - Locations where a radiation, an X-ray, a strong radio wave or a strong magnetic field is generated
 - Locations near coasts directly subjected to sea breezes, or locations subject to corrosive gases such as from hot springs, volcanic regions, etc.
 - Locations where the temperature is not within $-10\text{ }^{\circ}\text{C}$ - $+50\text{ }^{\circ}\text{C}$ { $14\text{ }^{\circ}\text{F}$ - $122\text{ }^{\circ}\text{F}$ }.
 - Locations subject to vibrations, such as on vehicles, marine vessels, or above product lines (This product is not designed for on-vehicle use.)
 - Locations where it may get wet from rain or water splash (including under the eaves, etc.)
 - Locations subject to moisture or dust
 - Locations subject to condensation as the result of severe changes in temperature (In case of installing the product in such locations, the front cover may become foggy or condensation may be caused on the cover.)
- The screws and bolts must be tightened with an appropriate tightening torque according to the material and strength of the installation area. After tightening the screws or bolts, perform visual check to ensure tightening is enough and there is no backlash.
- The pull-out strength of the installation area shall be 196 N {44 lbf} or more per 1 screw.

Parts and functions

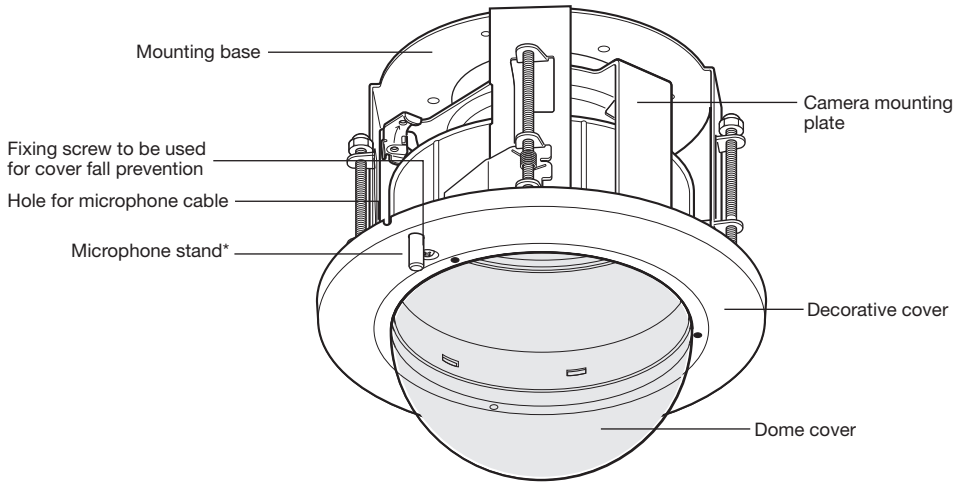

* If a tiepin type microphone is used, mount the microphone on the rubber-made microphone stand. Unless the microphone is used, cut the rubber with a nipper or conduct another treatment.

<Installation sample>

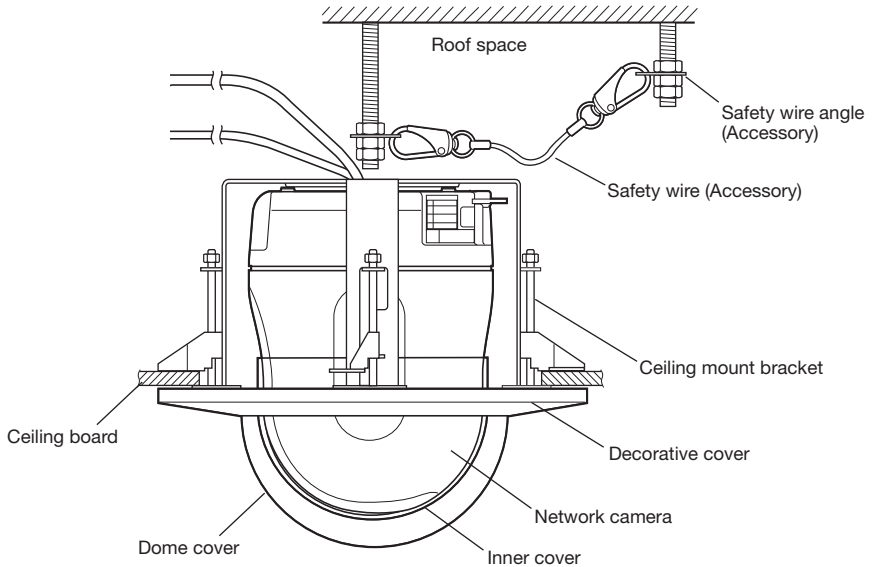

Installations

Be sure to read "Precautions" and "Precaution for installation" before installation. The Installation Guide of the network camera shall be read as well.

1. Remove the decorative cover.

- ① Loosen the fixing screw (unremovable) to be used for cover fall prevention.

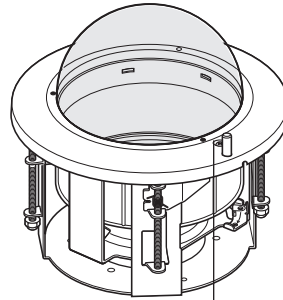

- ② Unhook the decorative cover from the hooks (3 positions) of the camera mounting plate and remove the decorative cover by turning it counterclockwise.

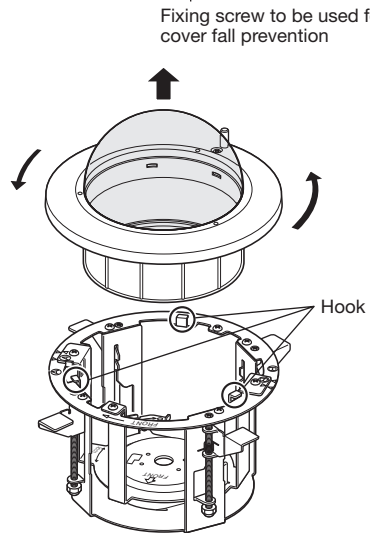

- ③ Take the inner cover out.

2. Remove the camera mounting plate.

Remove the screws (M4, 3 positions) and remove the camera mounting plate by turning it counterclockwise.

Remove the tab of the camera mounting plate (a) from the hole of the mounting base (b) (2 positions).

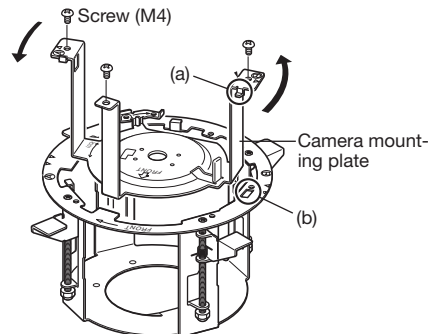

3. Put Template A (accessory) against the ceiling and make a hole.

- ① Make 4 holes of 12 mm {1/2 inches} in diameter.
- ② Remove the center part from the template.
- ③ Make a hole of 160 mm {6-5/16 inches} in diameter.

* The hole shape is shown below.

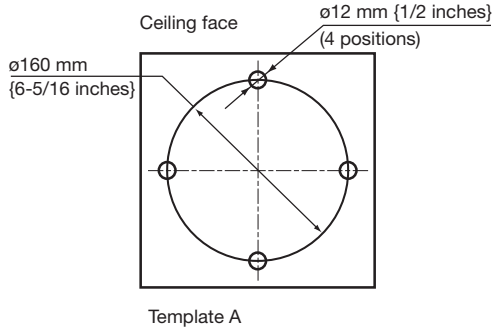
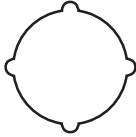

4. Install two anchor bolts (M10 recommended) into the concrete ceiling.

- ① Determine the anchor bolt length by use of Template B (accessory).
- ② Position the nut by use of Template B (accessory). (The distance between the bottom surfaces of the ceiling board and nut shall be 136 mm {5-3/8 inches}.)

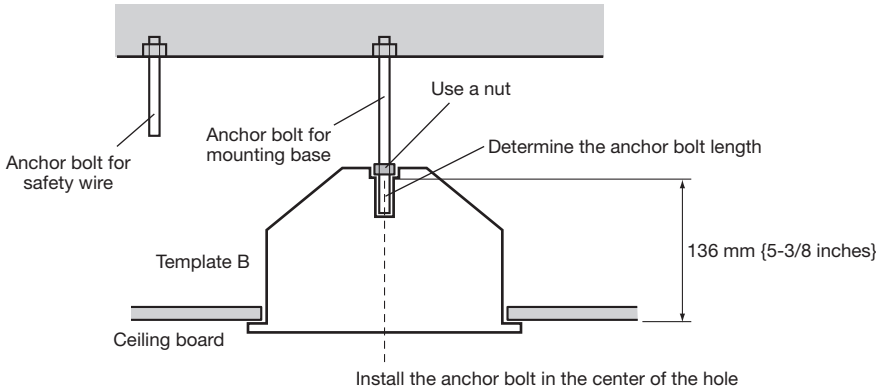

Note: If there is already an anchor bolt installed, it can be used as an anchor bolt for the safety wire. Make sure that the distance between the anchor bolt for the mounting base and the anchor bolt for the safety wire is 1 m {3.28 feet} or less before use.

5. Mount the safety wire angle (accessory) on the anchor bolt for the safety wire and connect the safety wire (accessory) to the angle.

- ① Disconnect the safety wire from the safety wire angle.
- ② Engage the face marked ❶ with the anchor bolt.
- ③ Bend the face marked ❷.
- ④ Connect the safety wire to the safety wire angle again.

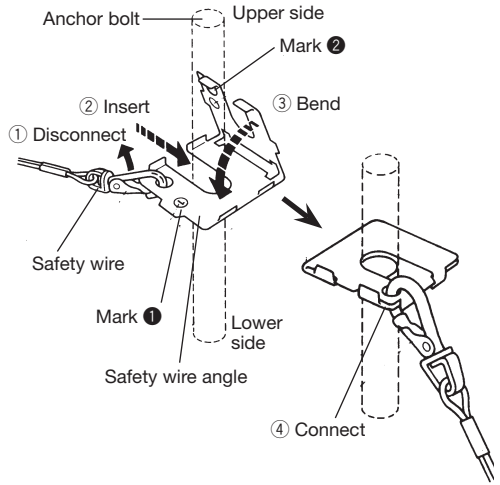

Note: To use the anchor bolt that was already installed, the use of 2 spacer nuts is helpful.

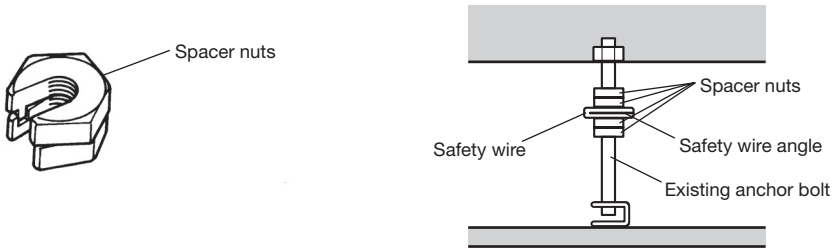

6. Connect the mounting base to another tip of the safety wire.

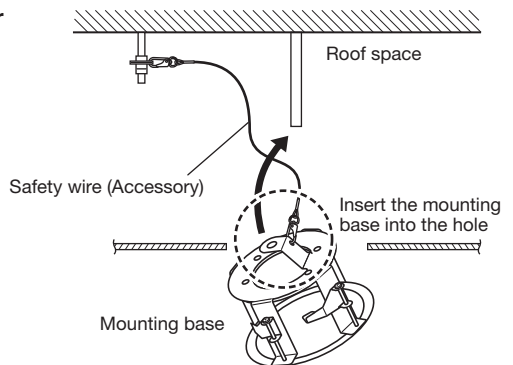

7. Insert the mounting base into the hole made in Step 3.

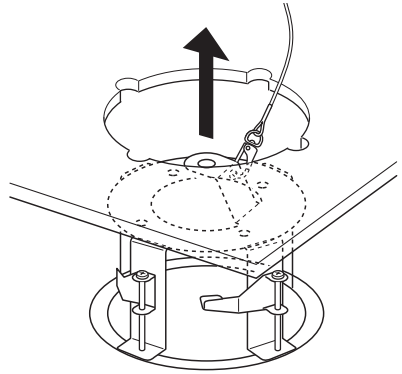

8. Secure the mounting base to the ceiling board with the ceiling board fixing screws (4 positions).

- ① Engage the top of the mounting base with the anchor bolt for the mounting base.
- ② Secure the mounting base by turning the ceiling board fixing screws clockwise.

Turning the ceiling board fixing screws clockwise provides ceiling board tightening between the bottom of the mounting base and the ceiling board fixing bracket resulting in mounting base securing.

(Recommended tightening torque:
0.78 N·m {0.58 lbf·ft})

- ③ Secure the top of the mounting base with double nuts.

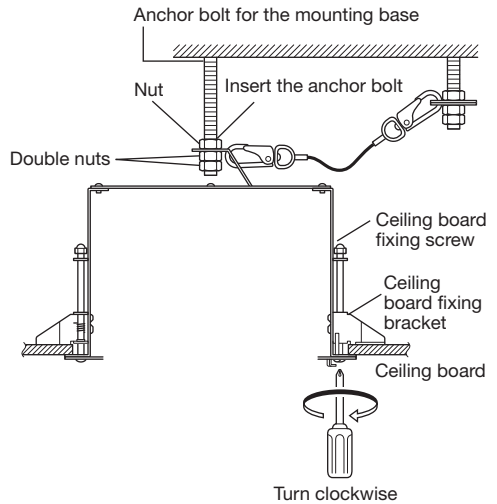

Important: When securing this bracket on the ceiling, make sure that the four ceiling board fixing brackets are open as shown in the figure.

9. Prepare the cables.

Run the cables from the cable inlet.

Important: The cables shall be run from the opposite side of the mark, FRONT. Failure to observe this makes the cables unconnectable since the camera faces the opposite side.

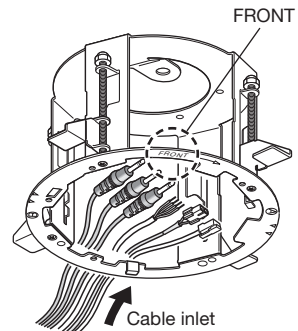

10. Install the inner cover.

Slide the covers located on the both lateral sides of the camera and put the inner cover on the camera until the hooks inside the inner cover are held in the holes of the camera (until a click is heard).

Important: Put the inner cover down on the camera until the outside cover of the camera cannot be seen from the opening (from which the camera lens is visible) of the inner cover. If this integration is not successfully performed, the inner cover may be removed or the hidden part at the top of the screen may become larger in the WIDE mode.

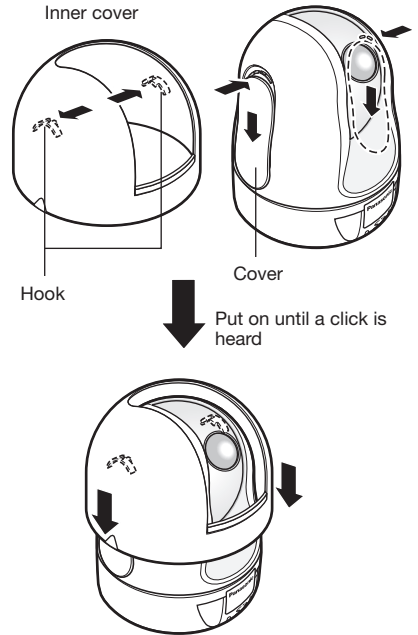

How to remove the inner cover

Press the inner cover from the front and rear sides inward (at the same vertical position as the hooks) to bend the cover and remove the cover from the camera.

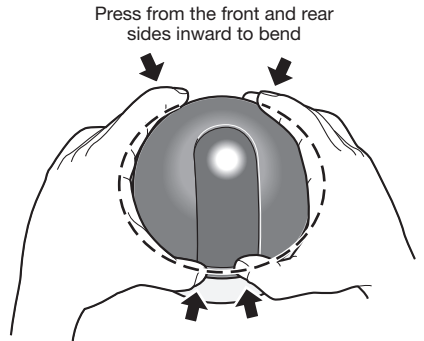

11. Mount the camera on the camera mounting plate.

- ① Put the camera onto the camera mounting plate with aligning the lock plate of the camera with the guide of the camera mounting plate and aligning the center of the camera mounting plate with the center of the screw for tripod mounting, and turn the camera clockwise.
- ② Secure the camera with 1 piece of the camera fixing screw (supplied with the camera).
(Recommended tightening torque: 0.68 N·m {0.58 lbf·ft})

Important: Be sure to mount the camera with holding the stationary portion of the camera. Camera mounting with holding the rotating portion of the camera may cause trouble.

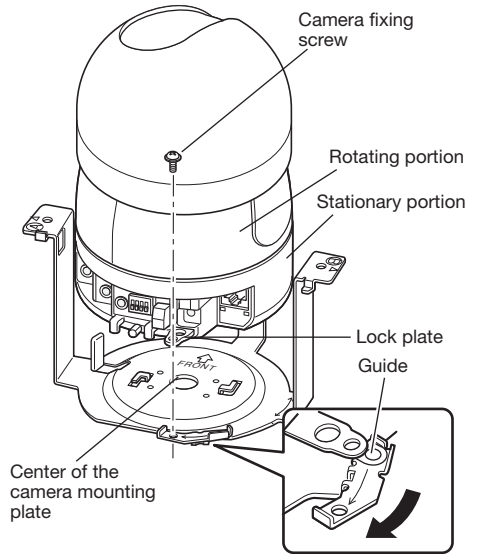

12. Connect the safety wire to the camera.

- ① Connect the safety wire locked on the mounting base to the camera. Make sure that the apical ring of the safety wire is engaged with the safety wire hook of the camera by pulling the safety wire after connection.

13. Connect the cables to the camera.

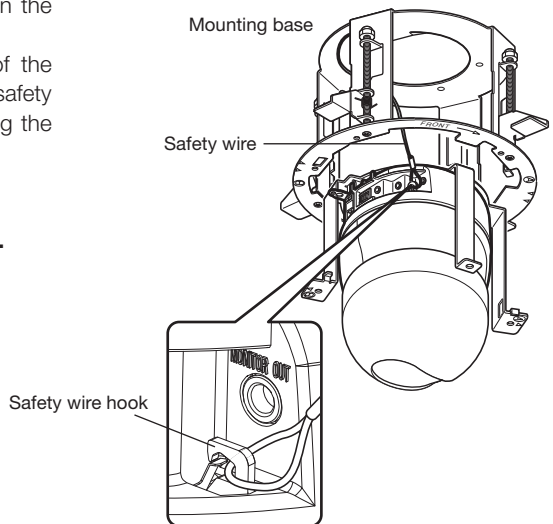

14. Mount the camera mounting plate on the mounting base.

- ① Align the marks (A to A and B to B) between the camera mounting plate and mounting base.
- ② Mount the camera mounting plate on the mounting base with aligning Δ of the camera mounting plate with "START ∇ " of the mounting base.
- ③ Turn the camera mounting plate until Δ of the camera mounting base aligns with "END ∇ " of the mounting base.
- ④ Tighten the 3 screws that were removed in Step 2.
(Recommended tightening torque:
1.6 N·m {1.18 lbf·ft})

Important: Do not let the cables be caught during installation work.

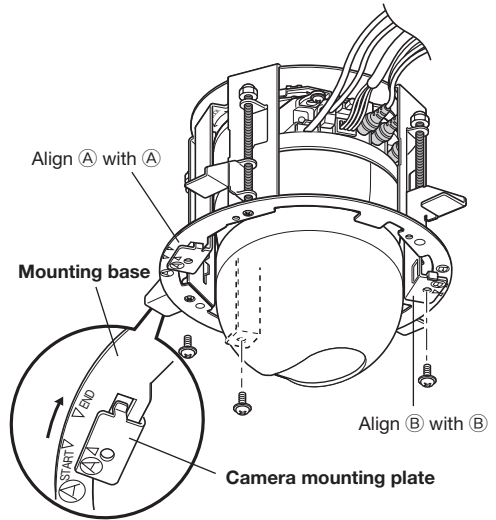

15. Mount the decorative cover.

- ① Mount the decorative cover on the camera mounting plate with engaging the projections of the decorative cover with the hooks for the decorative cover.
- ② Turn the decorative cover clockwise while pressing the projections upward and the cover is locked.

Important: The mark, "FRONT", shall be aligned with the Panasonic logo.

16. Tighten the fixing screw to be used for cover fall prevention.

(Recommended tightening torque:
1.6 N·m {1.18 lbf·ft})

17. Remove the protection sheet from the dome cover.

Remove the cover film from the dome cover after the installation is completed.

Note: When the camera lens is pointed in the horizontal direction, the inner cover interferes with the camera's view, and consequently about upper half of the monitor screen is hidden in the WIDE mode.

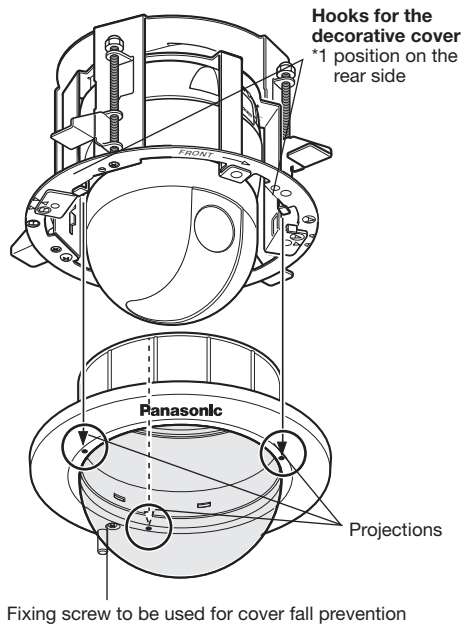

Specifications

Ambient temperature:	-10 °C to + 50 °C {14 °F to 122 °F}		
Dimensions:	ø190 mm x 212 mm (H) {ø7-15/32 inches x 8-11/32 inches (H)}		
Mass:	Approx. 800 g {1.77 lbs.}		
Finish:	Main body	:	Treatment steel
	Decorative cover	:	ABS resin with silver metallic coating
	Dome cover	:	PMMA resin Clear WV-Q159C Smoke WV-Q159S

Standard Accessories

Operating Instructions (this book) 1 pc.

The following are for installation

Safety wire 1 pc.

Safety wire angle 1 pc.

Template A 1 sheet

Template B 1 sheet

Inner cover 1 pc.

For U.S. and Canada:

**Panasonic i-PRO Sensing Solutions
Corporation of America**

800 Gessner Rd, Suite 700 Houston, TX 77024
<https://www.security.us.panasonic.com/>

Panasonic Canada Inc.

5770 Ambler Drive, Mississauga, Ontario, L4W 2T3 Canada
1-877-495-0580
<https://www.panasonic.com/ca/>

For Europe and other countries:

Panasonic Corporation

<http://www.panasonic.com>

Panasonic i-PRO Sensing Solutions Co., Ltd.
Fukuoka, Japan

Authorised Representative in EU:

Panasonic Testing Centre
Panasonic Marketing Europe GmbH
Winsbergring 15, 22525 Hamburg, Germany